

STS 16 STS 32

Static Transfer Switches
1ph from 16 to 32 A



Features and benefits

- Dual redundant power supplies to control boards, for increased availability.
- Redundant cooling and fan failure monitoring, for reliable operation.
- Real-time SCR fault sensing, preventing fault propagation.
- High overload capability, for robust electrical design.
- ITS maintenance switch, for hot swap maintainability.
- Compact 19" rack system design, for easy integration.

- LCD/LED display, providing user friendly interface.
- Comprehensive set of communication options for total remote monitoring of equipment operation.

Main options

- 100/110/115/120/127 Vac nominal voltage and NEMA sockets.
- ITS maintenance switch.
- RS485 ModBus interface.
- SNMP interface.

STS 16-32 front view



STS 16 rear view



STS 32 rear view



STS block diagram

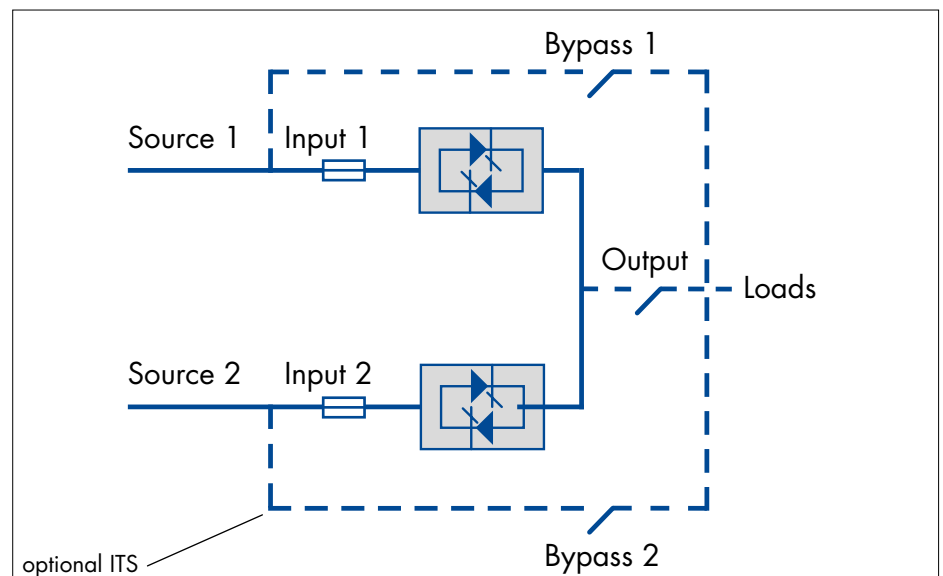

ITS maintenance switch

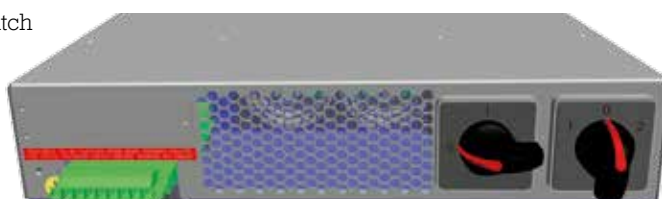

ITS maintenance switch main features

- 16 A and 32 A version.
- 6 x 40 A input terminal board.
- Zero switching time.

STS 16 - STS 32 technical data

Model	STS 16	STS 32
Rating (A)	16	32
Dimensions WxDxH (mm)	440x275x88	
Weight (kg)	8	9

Input	
Connection type	Hardwired 5w
Nominal voltage	200/208/220/230/240 Vac 1-phase
Voltage tolerance	± 5% (up to ±20%)
Absolute maximum voltage range	150 Vac to 300 Vac
Frequency and range	50/60 Hz, ± 5% (up to ±20%)
Source harmonic voltage content	Unlimited
Transfer phase angle	5° to 20°

Output	
Connection type	8 IEC-C 13, hardwired 3w
Nominal voltage	200/208/220/230/240 Vac 1-phase
Frequency	50/60 Hz
Transfer time	2 to 6 ms
Transfer mode	Break before make, transfer inhibit on fault
Load power factor	1 to 0.3
Maximum crest factor	3:1
THD current feedback from load	Unlimited
Overload capacity	125% for 10 min, 150% for 1 min, 700% for 0.6 s
Efficiency (AC/AC)	99%

Connectivity and function extensions	
Front panel	Graphical LCD display
Remote communication	Included: RS-232 ModBus, USB, voltage free relay contacts; Optional: one slot for SNMP adapter or RS-485 ModBus adapter

System	
Protection degree	IP 20
Colour	RAL 9005
Installation layout	Rack mounted
Accessibility	Front and rear

Other features

Environmental	
Operating temperature range	-5°C to +40°C
Storage temperature range	-10°C to +70°C
Altitude (AMSL)	< 1000 m without power reduction, > 1000 m with reduction of 0.5% per 100 m
Audible noise at 1 m (dBA)	<60

Standards and Certifications	
Quality assurance, environment, health and safety	ISO 9001:2008, ISO 14001:2004, BS OHSAS 18001:2007
Safety	IEC 60950-1
EMC	EN 55022, EN 55024
Transfer voltage limit	IEEE Standard 446
Protection degree	IEC 60529
Performance	IEC/EN 62310-3
Marking	CE